

2.22L 5-CYL TURBO & 2.3L 5-CYL

Article Text

1990 Audi 100

For atsg&cvt

Copyright © 1998 Mitchell Repair Information Company, LLC

Sunday, July 02, 2000 12:10AM

ARTICLE BEGINNING

1989-90 AUDI ENGINES

2.22L 5-Cylinder Turbo & 2.3L 5-Cylinder

80, 90, 100, 200 Turbo

* PLEASE READ THIS FIRST *

NOTE: For engine repair procedures not covered in this article, see ENGINE OVERHAUL PROCEDURES - GENERAL INFORMATION article in the GENERAL INFORMATION section.

ENGINE IDENTIFICATION

Engine number is stamped on machined pad just below cylinder head on left side of block or right side near distributor. First 2 characters are the designates engine code.

ENGINE IDENTIFICATION CODES TABLE

Application	Engine Code
2.22L 5-Cylinder Turbo	
200 Turbo	MC
2.3L 5-Cylinder	
80 & 90	NG
100	NF

ENGINE R & I

NOTE: Transaxle is not removed with engine.

REMOVAL

1) Disconnect negative battery cable. Remove fuel filler tank cap. On all models except 100/200 non-turbo series, remove front grille, bumper and radiator support assembly. Set heater controls to hot and drain cooling system through lower radiator hose. Remove intake air duct.

2) Mark and remove all cooling system hoses. Remove radiator, fan shroud and fan as an assembly. Remove windshield washer reservoir assembly (if necessary). Mark and disconnect electrical connectors and vacuum hoses (as necessary). Leaving hoses attached, remove and secure power steering and A/C compressor (if equipped). Remove alternator with brackets.

3) Disconnect throttle, cruise and kickdown cable (if equipped). Keep fuel lines attached and remove cold start valve, fuel distributor (with air filter housing), control pressure regulator and fuel injectors. Install protector caps and plugs on injectors and

2.22L 5-CYL TURBO & 2.3L 5-CYL

Article Text (p. 2)

1990 Audi 100

For atsg&cvt

Copyright © 1998 Mitchell Repair Information Company, LLC

Sunday, July 02, 2000 12:10AM

cold start valve. Mark and remove distributor cap.

4) Remove crankshaft damper bolt. Remove 2 crankshaft pulley bolts and loosen the other 2 bolts. Tap lightly against 2 loosened bolts to loosen pulley and bolts and pulley. Remove front engine support mount (if equipped). Remove starter assembly. Remove torque converter-to-flex plate bolts (if equipped). Remove inlet pipe from exhaust manifold.

CAUTION: Match mark engine-to-engine mounts prior to removal, to assist in proper engine alignment at installation.

5) Remove lower engine-to-transaxle support bolts. Mark and disconnect shift control cables. Remove all but one easy to reach upper engine-to-transaxle mounting bolts. Support transaxle. Attach engine sling and support engine. Remove all remaining engine mounts. Remove remaining engine-to-transaxle mount bolt. Separate engine from transaxle and lift engine out of vehicle.

CAUTION: DO NOT reuse antifreeze if cylinder block, cylinder head, head gasket, radiator and/or heater core were replaced. If both engine and transaxle were removed, realignment is necessary.

INSTALLATION

To install, reverse removal procedure. Ensure engine mounts are installed as marked at removal. Before final tightening of mounts, rock engine and transaxle back and forth lightly. Tighten engine mounts with engine running at idle. Fill fluids to proper level.

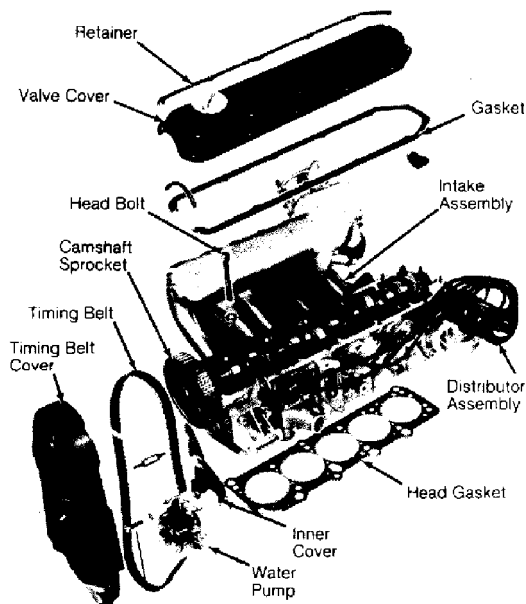

Fig. 1: Cylinder Head Assembly
Courtesy of Audi Of America, Inc.

2.22L 5-CYL TURBO & 2.3L 5-CYL

Article Text (p. 3)

1990 Audi 100

For atsg&cvt

Copyright © 1998 Mitchell Repair Information Company, LLC

Sunday, July 02, 2000 12:10AM

CYLINDER HEAD & MANIFOLDS R & I

REMOVAL

No removal procedure available from manufacturer. Cylinder head may be removed with engine in vehicle. Match mark all components for installation reference. Timing belt must be removed. See TIMING BELT R & I in this article. See Fig. 1. Remove cylinder head bolts in reverse sequence of installation. See Fig. 2.

INSPECTION

Check cylinder head for warpage. Maximum warpage is .004" (.10 mm). Minimum thickness of head, measured from head gasket surface to valve cover gasket surface, is 5.226" (132.75 mm). If not within specifications, replace cylinder head.

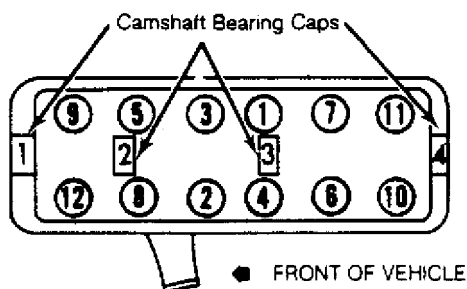

Fig. 2: Cylinder Head Tightening Sequence
Courtesy of Audi Of America, Inc.

CAUTION: Always replace head bolts. Polygon head bolts do not require retorquing procedure at 1000 mile service following repair.

INSTALLATION

1) Install head gasket dry with part number facing upward. Use locating pins to hold gasket in place. Before installing cylinder head, turn crankshaft until all pistons are about equal distance from TDC. This will prevent any open valves from hitting pistons.

2) Position head correctly and install bolts No. 9 and 11 to align head. Remove locating pins and install remaining bolts. Tighten cylinder head bolts in sequence to specifications. See Fig. 2. See TORQUE SPECIFICATIONS table at end of this article.

3) Set engine to TDC of compression stroke on No. 1 cylinder. Turn camshaft until timing mark on sprocket is aligned with upper edge of valve cover gasket (or rear timing belt cover). See Fig. 3. Install water pump with NEW sealing "O" ring, leaving bolts loose enough to move pump body.

4) Install timing belt. Turn water pump body counterclockwise to increase belt tension. Tension is correct when belt can be twisted 90 degrees using finger pressure at point midway between camshaft sprocket and water pump sprocket. Recheck valve

2.22L 5-CYL TURBO & 2.3L 5-CYL

Article Text (p. 4)

1990 Audi 100

For atsg&cv

Copyright © 1998 Mitchell Repair Information Company, LLC

Sunday, July 02, 2000 12:10AM

timing. To complete installation, reverse removal procedure.

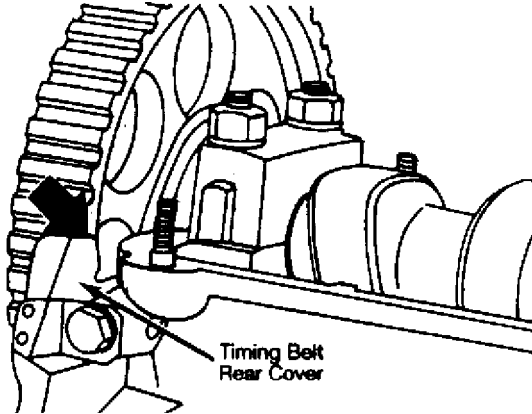

Fig. 3: Aligning Camshaft Sprocket
Courtesy of Audi Of America, Inc.

TIMING BELT COVER R & I

Remove upper radiator cover. Remove all drive belts from pulleys. Remove power steering pump with pressure hoses connected. Position pump aside. Remove timing belt cover. To install, reverse removal procedure.

TIMING BELT R & I / VALVE TIMING

REMOVAL

1) Remove upper radiator cover. Remove drive belts. Remove power steering pump with pressure hoses connected. Position pump aside. Remove valve cover and outer timing belt covers. See Fig. 1.

2) Using crankshaft bolt, turn crankshaft clockwise to TDC of compression stroke on No. 1 cylinder. Align timing mark on back of camshaft sprocket with upper edge of gasket. See Fig. 3.

3) Loosen water pump adjusting bolts to relieve tension on timing belt. Remove timing belt. Remove water pump to check sealing "O" ring. Do not allow crankshaft or camshaft to move.

INSTALLATION & VALVE TIMING

1) Both camshaft lobes on No. 1 cylinder must point upward. Mark (notch or dot) on back of camshaft sprocket must be aligned with top of valve cover gasket or rear timing belt cover. Crankshaft must be at TDC for No. 1 cylinder. Flywheel TDC mark must be aligned with index point on transmission housing.

2) Install water pump with new sealing "O" ring. Install timing belt. Turn water pump body counterclockwise to increase belt tension. Tension is correct when belt can be twisted 90 degrees using finger pressure at point midway between camshaft sprocket and water pump sprocket. Recheck valve timing. Complete installation in reverse order of removal.

2.22L 5-CYL TURBO & 2.3L 5-CYL

Article Text (p. 5)

1990 Audi 100

For atsg&cvt

Copyright © 1998 Mitchell Repair Information Company, LLC

Sunday, July 02, 2000 12:10AM

CAMSHAFT R & I

REMOVAL

Remove timing belt. If necessary, mark camshaft bearing caps No. 1 to No. 4 (front to rear). Loosen nuts holding No. 2 and No. 4 caps in diagonal pattern. Remove No. 2 and No. 4 caps. Loosen nuts holding No. 1 and No. 3 caps in diagonal pattern. Remove No. 1 and No. 3 caps. Remove camshaft from head.

INSTALLATION

1) Lubricate bearing surfaces in caps and camshaft journals. Install camshaft. Ensure oil spray jet is situated so that spray direction is at 90 degrees to camshaft. Install all bearing caps in original positions and correctly aligned.

2) Ensure caps are aligned correctly. See Fig. 4. Lightly tighten No. 2 and No. 4 caps in diagonal pattern. Tighten nuts on all 4 caps in diagonal pattern. Install remaining components. Set valve timing.

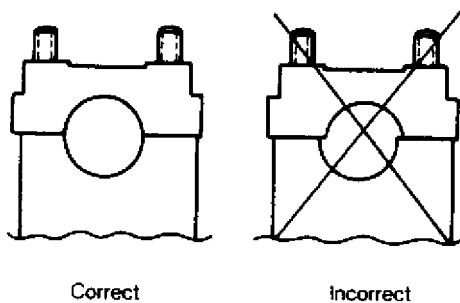

Fig. 4: Alignment of Camshaft Bearing Cap
Courtesy of Audi Of America, Inc.

CAMSHAFT OIL SEAL R & I

REMOVAL

1) Remove timing belt cover and valve cover. Position No. 1 piston on TDC. Loosen camshaft sprocket bolt while keeping camshaft from moving. Loosen water pump adjusting bolts to relieve tension on timing belt.

2) Remove timing belt. Remove water pump to check sealing ring. Remove camshaft sprocket and Woodruff key. Install sprocket bolt 3 turns into end of camshaft and secure with lock nut. Use Seal Extractor (2085) to remove camshaft oil seal.

3) Back inner portion of extractor 3 or 4 turns out from outer portion. Lock inner part with set screw on outer part. Lubricate threaded head of seal extractor and thread it into seal while pushing against end of extractor. Loosen set screw and turn inner part of extractor until seal comes out.

2.22L 5-CYL TURBO & 2.3L 5-CYL

Article Text (p. 6)

1990 Audi 100

For atsg&cvt

Copyright © 1998 Mitchell Repair Information Company, LLC

Sunday, July 02, 2000 12:10AM

INSTALLATION

1) Lubricate seal lips and seal recess with oil. Use Seal Installer (10-203) to press seal into place until flush with chamfered edge of head.

2) Install water pump and timing belt. Adjust valve timing and belt tension. Install remaining parts in reverse of removal procedure.

CAMSHAFT INSPECTION

END PLAY

Remove valve lifters. Check camshaft end play. If end play exceeds limit, check camshaft thrust flange and bearing cap for wear. Replace worn components.

CAUTION: Hydraulic valve lifters are always stored with contact face down. This applies to new lifters or to lifters removed for engine repairs. Lifters will take about 30 minutes to leak down after installation. DO NOT start engine during leak-down period as internal engine damage will occur.

OIL CLEARANCE

1) Remove camshaft and valve lifters. Keep lifters in order for reassembly. Place hydraulic lifters on clean surface with contact faces down. Remove sprocket and oil seal from camshaft. Clean bearing caps, bearing seats and camshaft journals.

2) Place camshaft on cylinder head. Ensure lobes do not touch valves or valve spring retainers. Place Plastigage on camshaft journals parallel to length of camshaft. Install bearing caps in correct position and tighten cap nuts. DO NOT rotate camshaft with Plastigage installed.

3) Remove bearing caps and read clearance. If wear limit is exceeded, repeat measurement with new camshaft installed. If wear limit is still exceeded with new camshaft, cylinder head must be replaced.

VALVE ARRANGEMENT

E-I-E-I-I-E-I-E-I-E (Front-to-rear).

VALVE GUIDES R & I

REMOVAL

Use press and Valve Guide Drift (10-206) to remove and install guides. Press guides out from combustion chamber side of head.

2.22L 5-CYL TURBO & 2.3L 5-CYL

Article Text (p. 7)

1990 Audi 100

For atsg&cvt

Copyright © 1998 Mitchell Repair Information Company, LLC

Sunday, July 02, 2000 12:10AM

INSPECTION

1) Clean valve guides. Attach dial indicator and Adapter (VW 387) to mounting surface of cylinder head. Insert new valve into valve guide. End of valve stem must be flush with end of valve guide.

2) Rock valve head back and forth against tip of dial indicator to measure clearance between stem and guide. If reading exceeds limits, replace guides and/or valves. See VALVES specifications at end of article.

INSTALLATION

Coat new guides with oil. Press guides into head from camshaft side. Press guides in as far as possible. Do not use more than one ton of pressure after guide shoulder is seated as guide shoulder may break. Ream guide by hand to proper size.

VALVE & SEAT REFACING

CAUTION: NEVER rework exhaust valves on machine. Lap exhaust valves by hand only.

1) If intake valves are to be refaced, they must exceed minimum standards. Measure intake valve stem diameter. Measure exhaust valve stem diameter. Measure overall length of valves. See VALVES specifications at end of article.

2) One of 2 limits for cutting valve seats (dimension "y") is determined by measured distance "X" between stem end of closed stem and upper face of cylinder head (where valve cover gasket rests). See Fig. 5. Insert valve into guide and hold tightly against seat.

3) Measure distance "X". Subtract minimum dimension "X" from measured distance "X". Result is maximum cut allowed (dimension "y") for refacing valve seats. Minimum dimension "X" is 1.33" (33.8 mm) for intake valves and 1.34" (34.1 mm) for exhaust valves.

NOTE: If minimum dimension "X" is greater than measured distance "X", cylinder head must be replaced. If minimum dimension is not observed, hydraulic valve lifters may not function properly.

2.22L 5-CYL TURBO & 2.3L 5-CYL

Article Text (p. 8)

1990 Audi 100

For atsg&cvt

Copyright © 1998 Mitchell Repair Information Company, LLC

Sunday, July 02, 2000 12:10AM

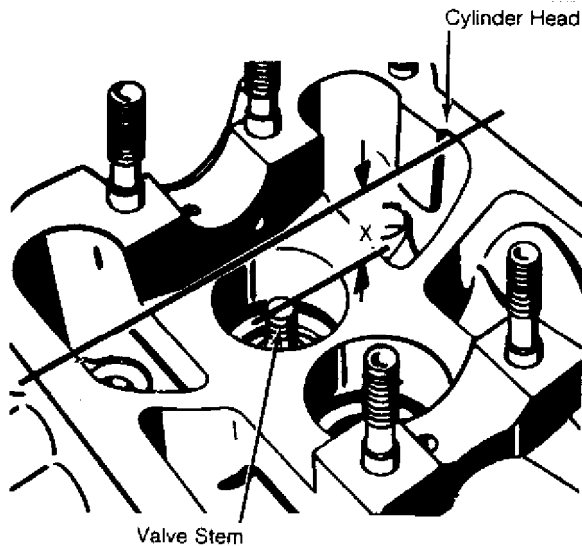

Fig. 5: Measuring Refacing Limit of Valve Seats
Courtesy of Audi Of America, Inc.

4) On all models, second limit for maximum amount of material that may be removed from seat is determined by distance "D" from lower face of cylinder head to edge of 45 degrees valve seat angle. See Fig. 6. Maximum distance "D" for intake seats is .36" (9.2 mm). Maximum distance "D" for exhaust seats is .35" (9.0 mm).

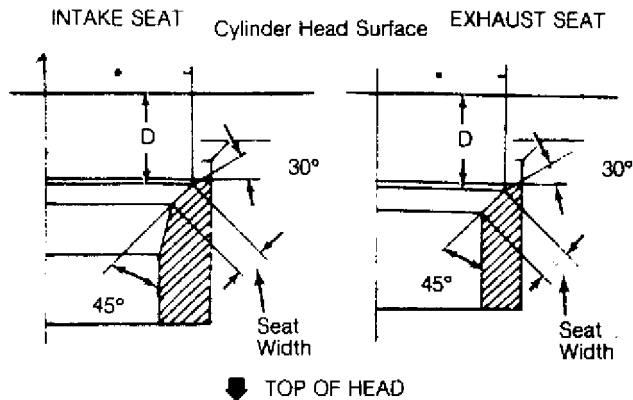

Fig. 6: Measuring Refacing Limits of Valve Seats
Courtesy of Volkswagen United States, Inc.

5) Do not reface exhaust valves on machine. Lap exhaust valves only by hand. Be sure to remove all traces of grinding compound from valves and guides after valves have been lapped into seats.

VALVE STEM OIL SEALS R & I

NOTE: Valve stem seals may be replaced with cylinder head installed on vehicle.

2.22L 5-CYL TURBO & 2.3L 5-CYL

Article Text (p. 9)

1990 Audi 100

For atsg&cvt

Copyright © 1998 Mitchell Repair Information Company, LLC

Sunday, July 02, 2000 12:10AM

CAUTION: All hydraulic valve lifters are always stored with contact face down. Lifters take about 30 minutes to leak down after installation. DO NOT start engine until leak-down period has occurred.

REMOVAL

1) Remove camshaft. Remove hydraulic lifters. Keep in order for reassembly. Remove spark plug of cylinder to be serviced. Turn crankshaft until piston is at BDC.

2) Install air hose and Adapter (VW 653/3) in spark plug hole and apply line pressure of at least 87 psi. Do not remove line pressure until valve spring components are reassembled.

CAUTION: Be aware that engine can rotate due to air pressure if piston is not at true BDC. Keep hands clear of belts and pulleys.

3) Use Spring Compressor (VW 541/1 or 2036). Compress valve spring and remove keepers, retainers and springs. Take out seals with Seal Remover Pliers (10-218).

INSTALLATION

Slide protective plastic sleeve onto valve stem. Lubricate new seal and push into place with Seal Installer (10-204). Install remaining components in reverse order of removal. Ensure valve timing is correct.

HYDRAULIC VALVE LIFTER CHECK

NOTE: Hydraulic valve lifters are not repairable or adjustable. Any worn, damaged or noisy lifter must be replaced as complete assembly. Some occasional valve/lifter noise is normal immediately after starting engine.

INSPECTION

1) Run engine until radiator cooling fan has cycled at least once. Hold engine at steady 2500 RPM for 2 minutes. Allow engine speed to return to idle. If lifter is still noisy, replace it.

2) Remove valve cover. Rotate crankshaft until both camshaft lobes of cylinder to be checked point upward. Push down on lifters with wooden stick. If lifter compresses more than .004" (.10 mm), it must be replaced.

3) If hydraulic valve lifters are removed for engine repairs, keep them in correct order for reassembly. Store lifters on clean surface with contact surface facing down. This is upside down compared to installed position.

OIL PAN R & I

2.22L 5-CYL TURBO & 2.3L 5-CYL

Article Text (p. 10)

1990 Audi 100

For atsg&cvt

Copyright © 1998 Mitchell Repair Information Company, LLC

Sunday, July 02, 2000 12:10AM

REMOVAL

Remove 2 front bolts of subframe. Drain engine oil. Remove dipstick. Remove flywheel dust cover. Remove rear pan bolts. Remove remaining pan bolts and lower pan from engine.

INSTALLATION

Clean all gasket mating surfaces. Make sure flange of oil pan is not distorted. Install oil pan with new gasket. Tighten pan bolts in criss-cross pattern. Replace dipstick and flywheel dust cover. Tighten subframe bolts.

PISTON & ROD ASSEMBLY R & I

REMOVAL

1) Drain oil and coolant. Remove cylinder head and oil pan. Place piston to be removed at bottom of cylinder and cover with cloth to collect metal cuttings. Use ridge reamer to remove ridge or deposit from upper end of cylinder bore.

2) Before removing piston and rod from engine, mark rod and rod cap for cylinder identification. Remove rod cap and carefully push piston and rod out top of cylinder. Loosely install rod cap to rod for reassembly.

PISTON IDENTIFICATION

Piston recess is measured from face of piston, to bottom of dish in top of piston. The compression height of these pistons, is measured from face of piston to top of wrist pin opening. See PISTON IDENTIFICATION table.

INSTALLATION

1) Coat cylinder bore, piston and rings with engine oil. Ensure ring end gaps are spaced 120 degrees apart. Install ring compressor on piston, making sure position of rings does not change.

2) Install piston and rod in original bore. Arrow on piston head faces toward front of engine. Forged marks (lumps) on rod and cap must also face toward front of engine. Make sure connecting rod bolts do not damage bearing journals on crankshaft.

PISTON IDENTIFICATION TABLE

Engine	Recess	Compression Height
MC	15 mm	30 mm
KX, JT	8.1 mm	22.2 mm
NF	4.4 mm	33.3 mm

2.22L 5-CYL TURBO & 2.3L 5-CYL

Article Text (p. 11)

1990 Audi 100

For atsg&cvt

Copyright © 1998 Mitchell Repair Information Company, LLC

Sunday, July 02, 2000 12:10AM

FITTING

1) Measure cylinder out-of-round. Limit for cylinder out-of-round is .0016" (.040 mm). Determine piston-to-cylinder clearance. Block must be bored and oversize pistons installed if clearance is excessive. See ENGINE SPECIFICATIONS tables at end of this article.

NOTE: Cylinder bore dimensions should not be measured with engine mounted on stand as readings may be incorrect due to distortion of block.

2) Different oversizes of pistons are available, depending upon engine application. See PISTON & CYLINDER DIMENSIONS table for available pistons and correct bore dimensions.

PISTON & CYLINDER DIMENSIONS TABLE

AA

Size	Piston Diameter	Cylinder Bore
------	-----------------	---------------

2.22L

Standard 80.98 mm 81.01 mm
1st Over 81.23 mm 81.26 mm
2nd Over 81.48 mm 81.51 mm

2.3L

Standard 82.48 mm 82.51 mm
1st Over 82.74 mm 82.76 mm
2nd Over 82.98 mm 83.01 mm

AA

FITTING RINGS

Measure piston ring end gap. Measure ring side clearance. Install compression rings on piston with "TOP" mark facing upward. Recessed edge on outside of center ring must face down toward piston pin. Oil scraper ring can be installed either way. Space ring end gaps 120 degrees apart.

PISTON PIN REPLACEMENT

REMOVAL

Remove circlip from pin bore groove. Use Piston Pin Drift (VW 207C) to remove and install piston pin. If pin is too tight, warm pistons to about 140°F (60°C) and then install pin.

INSTALLATION

Assemble connecting rod to piston. Arrow on piston head and forged marks on connecting rod must face toward front of engine when assembly is installed. Use pin drift to install piston pin. Install

2.22L 5-CYL TURBO & 2.3L 5-CYL

Article Text (p. 12)

1990 Audi 100

For atsg&cvt

Copyright © 1998 Mitchell Repair Information Company, LLC

Sunday, July 02, 2000 12:10AM

circlip into pin bore groove.

MAIN BEARINGS

1) Main bearing caps are numbered one through 6 (front to rear). Never interchange bearing caps. Use Plastigage method for measuring bearing clearances. See ENGINE SPECIFICATIONS tables at end of this article.

2) When replacing bearings, install grooved bearing halves into cylinder block. Plain bearing halves are installed in main caps. Lubricate crankshaft journals and bearings prior to installation. For more information, refer to the OVERHAUL PROCEDURES article in this section.

CONNECTING ROD BEARINGS

Use Plastigage method for measuring bearing clearances. Use feeler gauge to check connecting rod side clearance. See ENGINE SPECIFICATIONS tables at end of this article.

CRANKSHAFT END PLAY CHECK

Use feeler gauge to check crankshaft end play. Insert feeler gauge between No. 4 main bearing (thrust bearing) and crankshaft journal thrust face. See ENGINE SPECIFICATIONS tables at end of this article.

FRONT CRANKSHAFT OIL SEAL R & I

REMOVAL

1) Remove lower grille. Remove timing belt cover. Loosen water pump to remove timing belt. Remove water pump to replace sealing "O" ring. Use Crankshaft Lock (2084) to hold crankshaft.

2) Remove crankshaft damper/pulley bolt with Spanner (2079). Remove pulley with belt drive sprocket. Using Seal Remover (2086), carefully pry seal from oil pump housing.

INSTALLATION

1) Lightly coat new seal lip and outer edge with oil. Using Seal Installer (2080) and Guide Sleeve (2080A), press in seal until seated. Install crankshaft damper with timing belt. Install water pump with new sealing ring. Mount crankshaft lock on crankshaft pulley.

2) Use Loctite 573 on crankshaft damper bolt and install. Use spanner and torque wrench to tighten crankshaft pulley bolt. Torque specification only applies if torque wrench handle and spanner are in a straight line.

3) Remove tools and adjust timing belt tension. Make sure valve timing is correct. Install remaining parts in reverse order of disassembly.

2.22L 5-CYL TURBO & 2.3L 5-CYL

Article Text (p. 13)

1990 Audi 100

For atsg&cvt

Copyright © 1998 Mitchell Repair Information Company, LLC

Sunday, July 02, 2000 12:10AM

REAR CRANKSHAFT OIL SEAL R & I

REMOVAL

Index mark flywheel or flex plate to crankshaft before removal. Remove flywheel or flex plate. Note position of any shims used. Using Seal Remover (2086), carefully pry oil seal from seal flange.

INSTALLATION

1) Coat lips of new seal with oil. Position seal in place and start by hand. Using Seal Installer (2003/1), press seal in until seated. There must be sufficient clearance between flex plate (A/T models) and back of engine block. Bolt torque converter tightly to crankshaft without shim.

2) Measure inside of drive plate from top edge of lip to face of plate where torque converter attaches. Measure from top edge of lip to engine block on both sides of block. Subtract inside measurement from outside measurement. If result is in range of .68-.74" (17.2-18.8 mm), no shim is required between flex plate and end of crankshaft. If result is smaller than range, shim is required.

3) Remove bolts and coat with locking compound. Install flywheel or flex plate with correct shim (if required) and tighten bolts. Note that notch on outer washer of flex plate faces toward torque converter on models with A/T. Replace shoulder bolts with new bolts. To complete installation, reverse removal procedure.

ENGINE OILING SYSTEM/SPECIFICATIONS

CRANKCASE CAPACITY

On all 100/200 series, capacity is 4.8 qts. (4.5L) with filter and 4.2 qts. (4.0L) without filter. On 80/90 models, capacity is 3.7 qts. (3.5L) with filter and 3.2 qts. (3.0L) without filter.

NOTE: Whenever turbocharger is replaced or rebuilt, engine oil and BOTH oil filters must be replaced.

OIL PRESSURE

Oil pressure is 29 psi (2.0 kg/cm²) at 2000 RPM. Measurement is to be made with fresh oil at temperature of 176°F (80°C).

OIL PRESSURE RELIEF VALVE

Oil pressure relief valve opens at 77-91 psi (5.3-6.3 kg/cm²).

OIL PRESSURE WARNING SYSTEM

2.22L 5-CYL TURBO & 2.3L 5-CYL

Article Text (p. 14)

1990 Audi 100

For atsg&cvt

Copyright © 1998 Mitchell Repair Information Company, LLC

Sunday, July 02, 2000 12:10AM

1) Dynamic oil pressure warning system is used on this motor. Control unit with buzzer is mounted on relay panel adapter. Dual oil pressure switches are on side of block.

2) Contacts of both switches are open with engine off. If oil pressure drops below 4.0 psi (.3 kg/cm²) while engine is running, contacts of Brown oil pressure switch will open. Buzzer will sound and oil pressure symbol will appear on instrument panel.

3) If oil pressure drops below 23-29 psi (1.6-2.0 kg/cm²) with engine running at 2500 RPM, contacts of White oil pressure switch will open. Buzzer will sound and oil pressure symbol will appear on instrument panel.

OIL PUMP R & I

REMOVAL

1) Remove all drive belts from crankshaft pulley. Remove power steering pump (with hoses connected) and position aside. Remove timing belt covers. Loosen crankshaft damper/pulley bolt.

2) Turn crankshaft to position No. 1 piston at TDC after compression stroke. Loosen water pump adjusting bolts. Turn water pump to relieve tension on timing belt.

3) Remove lower timing belt cover. Ensure crankshaft position has not changed. Remove damper/pulley from crankshaft with drive sprocket attached. Remove dipstick. Drain engine oil and remove oil pan. Remove oil suction tube from oil pump. Remove oil pump. See Fig. 7.

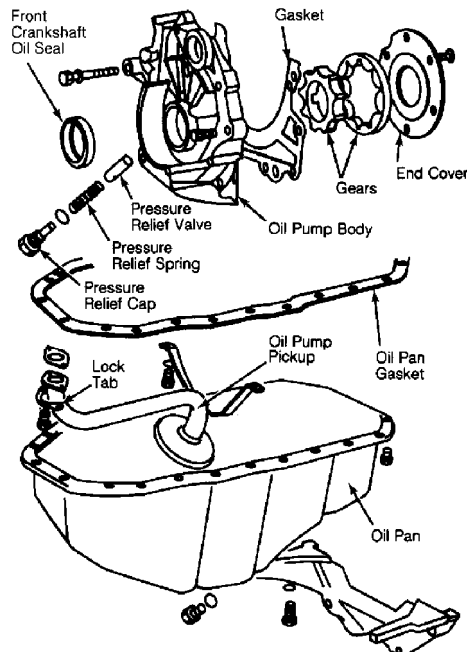

Fig. 7: Oil Pump, Pick-Up & Pan
Courtesy of Audi Of America, Inc.

2.22L 5-CYL TURBO & 2.3L 5-CYL

Article Text (p. 15)

1990 Audi 100

For atsg&cvt

Copyright © 1998 Mitchell Repair Information Company, LLC

Sunday, July 02, 2000 12:10AM

INSPECTION

Inspect end cover, housing and gears for wear or scoring. Replace end cover if scored. If pump gears require replacement, replace only as a set. No specifications

INSTALLATION

Prime oil pump prior to installing. Install oil pump in reverse of removal procedure. Coat the threads of the crankshaft damper/pulley bolt with Loctite prior to installing. Adjust timing belt tension. Ensure valve timing is correct.

WATER PUMP R & I

REMOVAL

1) Drain cooling system. Remove timing belt covers. Turn crankshaft to TDC for No. 1 cylinder. Align timing marks on flywheel and camshaft gear with reference marks.

2) Loosen water pump to relieve tension on timing belt. Remove timing belt. Do not allow crankshaft or camshaft to move. Remove water pump.

NOTE: If remanufactured water pump is being used, check "O" ring size. Some pumps are resurfaced and require a 5 mm "O" ring. These pumps will have numeral "5" stamped in mounting flange.

INSTALLATION

Install water pump in reverse of removal procedure, using new "O" ring. Ensure valve timing is correct prior to installing remaining components.

TORQUE SPECIFICATIONS

TORQUE SPECIFICATIONS TABLE

AA

Application	Ft. Lbs. (N.m)
Camshaft Bearing Cap Nuts (1)	15 (20)
Camshaft Sprocket Bolt	58 (80)
Connecting Rod Cap Nuts	37 (50)
Crankshaft Damper/Pulley Bolt (2)	(3) 258 (350)
Cylinder Head Bolts (4)(5)	
Step 1	29 (40)
Step 2	43 (60)
Step 3	Additional 180 Degrees (1/2 Turn)
Exhaust Manifold-to-Head Nuts	18 (25)
Exhaust Manifold-to-Turbocharger Nuts	43 (60)
Exhaust Pipe-to-Turbocharger Nuts	22 (30)

2.2L 5-CYL TURBO & 2.3L 5-CYL

Article Text (p. 16)

1990 Audi 100

For atsg&cvt

Copyright © 1998 Mitchell Repair Information Company, LLC

Sunday, July 02, 2000 12:10AM

Flywheel-to-Crankshaft Bolts (2)	
Without Shoulder	55 (75)
With Shoulder (5)	74 (100)
Intake Manifold Bolts	18 (25)
Main Bearing Cap Bolts	47 (65)
Oil Return Line	
Bracket-to-Turbocharger Nut	18 (25)
Oil Pump-to-Cylinder Block	15 (20)
Oil Pan-to-Block	15 (20)
Torque Converter-to-Flex Plate Bolts	22 (30)
Water Pump-to-Block	15 (20)

INCH Lbs. (N.m)

Rear Oil Seal Retainer	84 (10)
Suction Tube-to-Oil Pump	84 (10)
Timing Belt Cover	84 (10)

- (1) - Lightly tighten cap Nos. 2 and 4 evenly first, then tighten all to specifications.
- (2) - Use locking compound.
- (3) - Applies only when using Spanner (2079) and torque wrench. Torque wrench must be in-line with spanner handle.
- (4) - Tighten in sequence. See Fig. 2. Use locking compound.
- (5) - Always use new bolts.

AA

ENGINE SPECIFICATIONS

GENERAL ENGINE SPECIFICATIONS

GENERAL ENGINE SPECIFICATIONS TABLE

AA

Application In. (mm)

2.2L	
Displacement	
Cu. In.	136
Liters	2.22
Fuel System	CIS-L
HP @ RPM	162 @ 5500
Torque Ft. @ RPM	177 @ 3000
Compression Ratio	7.8:1
Bore	3.19 (81.0)
Stroke	3.40 (86.4)

2.3L	
Displacement	
Cu. In.	140
Liters	2.3
Fuel System	CIS-E III

2.22L 5-CYL TURBO & 2.3L 5-CYL

Article Text (p. 17)

1990 Audi 100

For atsg&cvt

Copyright © 1998 Mitchell Repair Information Company, LLC

Sunday, July 02, 2000 12:10AM

HP @ RPM 130 @ 5700
Torque Ft. @ RPM 140 @ 4500
Compression Ratio 10:1
Bore 3.25 (82.5)
Stroke 3.40 (86.4)

AA

CRANKSHAFT MAIN & CONNECTING ROD BEARINGS SPECS

CRANKSHAFT MAIN & CONNECTING ROD BEARINGS SPECS TABLE

AA

Application Specification

2.2L

Crankshaft

End Play

New or Rebuild003-.009 (.07-.23)

Wear Limit011 (.29)

Runout0010 (.025)

Main Bearings

Journal Diameter 2.281-2.282 (57.96-57.98)

Journal Out-of-Round0010 (.025)

Journal Taper0010 (.025)

Oil Clearance

New or Rebuild0010-.0020 (.025-.050)

Wear Limit006 (.16)

Connecting Rod Bearings

Journal Diameter 1.8094-1.8102 (45.958-45.978)

Journal Out-of-Round0010 (.025)

Journal Taper0010 (.025)

Oil Clearance

New or Rebuilt0004-.0020 (.010-.058)

Wear Limit005 (.12)

2.3L

Crankshaft

End Play

New or Rebuild003-.009 (.07-.23)

Wear Limit011 (.29)

Runout0010 (.025)

Main Bearings

Journal Diameter 2.281-2.282 (57.96-57.98)

Journal Out-of-Round0010 (.025)

Journal Taper0010 (.025)

Oil Clearance0010-.0020 (.025-.050)

New or Rebuild0010-.0020 (.025-.050)

Wear Limit006 (.16)

Connecting Rod Bearings

Journal Diameter 1.8802-1.8810 (47.758-47.778)

Journal Out-of-Round0010 (.025)

Journal Taper0010 (.025)

Oil Clearance0007-.0023 (.018-.058)

New or Rebuild0004-.0023 (.010-.058)

2.22L 5-CYL TURBO & 2.3L 5-CYL

Article Text (p. 18)

1990 Audi 100

For atsg&cvt

Copyright © 1998 Mitchell Repair Information Company, LLC

Sunday, July 02, 2000 12:10AM

Wear Limit005 (.12)

AA

PISTON, PINS & RINGS SPECIFICATIONS

PISTON, PINS & RINGS SPECIFICATIONS TABLE

AA

Application Specification

2.2L Pistons

Standard Size

Clearance (Maximum)0016 (.040)

Diameter 3.188 (80.98)

1st Oversize .010 (.025)

Clearance (Maximum)0016 (.040)

Diameter 3.198 (81.23)

2nd Oversize .020 (.050)

Clearance (Maximum)0016 (.040).

Diameter 3.208 (81.48)

2.3L Pistons

Standard Size

Clearance (Maximum)0016 (.040)

Diameter 3.247 (82.48)

1st Oversize .010 (.025)

Clearance (Maximum)0016 (.040)

Diameter 3.257 (82.74)

2nd Oversize .020 (.050)

Clearance (Maximum)0016 (.040)

Diameter 3.267 (82.98)

2.2L & 2.3L Piston Pins

Piston Fit Interference

2.2L & 2.3L Piston Rings

No.1 (Top Ring)

End Gap008-.020 (.20-.50)

Side Clearance0010-.0298 (.025-.075)

No.2 (2nd Ring)

End Gap008-.020 (.20-.50)

Side Clearance0010-.0298 (.025-.075)

No.3 (Oil Control)

End Gap008-.020 (.20-.50)

Side Clearance0010-.0020 (.025-.050)

AA

CYLINDER BLOCK SPECIFICATIONS

CYLINDER BLOCK SPECIFICATIONS TABLE

AA

Application Specification

2.2L

Cylinder Bore

Standard Diameter 3.189 (81.01)

2.22L 5-CYL TURBO & 2.3L 5-CYL

Article Text (p. 19)

1990 Audi 100

For atsg&cvt

Copyright © 1998 Mitchell Repair Information Company, LLC

Sunday, July 02, 2000 12:10AM

1st Oversize	3.199 (81.26)
2nd Oversize	3.209 (81.51)
Maximum Out-of-Round0030 (.075)

2.3L

Cylinder Bore

Standard Diameter	3.248 (82.51)
1st Oversize	3.258 (82.76)
2nd Oversize	3.268 (83.01)
Maximum Out-of-Round0030 (.075)

AA

VALVES & VALVE SPRINGS SPECIFICATIONS (1)

VALVES & VALVE SPRINGS SPECIFICATIONS TABLE (1)

AA

Application	Specification
-------------	---------------

2.2L

Intake Valves (2)

Face Angle	45°
Head Diameter	1.49 (38.0)
Length	3.58 (91.0)
Stem Diameter315 (8.00)

Exhaust Valves (2)

Face Angle	45°
Head Diameter	1.299 (33.00)
Length	3.575 (90.80)
Stem Diameter315 (8.00)

2.3L

Intake Valves (2)

Face Angle	45°
Head Diameter	1.575 (40.00)
Length	3.582 (91.00)
Stem Diameter315 (8.00)

Exhaust Valves (2)

Face Angle	45°
Head Diameter	1.299 (33.00)
Length	3.575 (90.80)
Stem Diameter315 (8.00)

(1) - Valve spring information not available.

(2) - Do not machine valves. Hand lap only.

AA

CYLINDER HEAD SPECIFICATIONS - 2.2L & 2.3L

CYLINDER HEAD SPECIFICATIONS TABLE - 2.2L & 2.3L

AA

Application	Specification
-------------	---------------

Cylinder Head Height	5.226 (132.75)
Maximum Warp	.006 (0.15)

2.2L 5-CYL TURBO & 2.3L 5-CYL

Article Text (p. 20)

1990 Audi 100

For atsg&cvt

Copyright © 1998 Mitchell Repair Information Company, LLC

Sunday, July 02, 2000 12:10AM

Valve Seats

Intake Valve

Seat Angle 45°
Seat Width080 (2.00)

Exhaust Valve

Seat Angle 45°
Seat Width094 (2.40)

AA

CAMSHAFT SPECIFICATIONS - 2.2L & 2.3L

CAMSHAFT SPECIFICATIONS TABLE - 2.2L & 2.3L

AA

Application	Specification
Bore Diameter	Not Available
End Play006 (0.15)
Radial Play004 (0.10)

AA

END OF ARTICLE